



## ASPS

# Auxiliary sensor power supply

### FEATURES

---

- From the Vibro-Meter® product line
- Auxiliary sensor power supply for VM600 racks
- Input voltage: 100 to 240 V<sub>AC</sub> (typical)
- Two independent 24 V<sub>DC</sub> outputs
- Internal redundancy (two AC-DC converters per output) for high availability
- Replaces an APF 19x and reduces external wiring



### DESCRIPTION

---

The auxiliary sensor power supply (ASPS) is a power supply unit with two 24 V<sub>DC</sub> outputs for use in the VM600 rack, from Meggitt Sensing Systems' Vibro-Meter product line.

The ASPS is mounted in the rear of the VM600 (ABE 04x) rack, adjacent to the rear panel of an AC input RPS 6U from which it takes an AC mains supply. Internally, each ASPS output consists of two AC-DC converters wired in parallel to ensure high

availability, while the dual independent outputs can provide redundancy.

The ASPS is designed to power external hardware such as front-end transducers and signal conditioners, GSI-type galvanic separation units and other hardware requiring a +24 V<sub>DC</sub> power supply.

Installed in a VM600 rack, the ASPS can replace an APF 19x mounted externally, thereby reducing wiring and simplifying the installation.



Information contained in this document may be subject to Export Control Regulations of the European Union, USA or other countries. Each recipient of this document is responsible for ensuring that transfer or use of any information contained in this document complies with all relevant Export Control Regulations. ECN N/A.

SYSTEM OVERVIEW

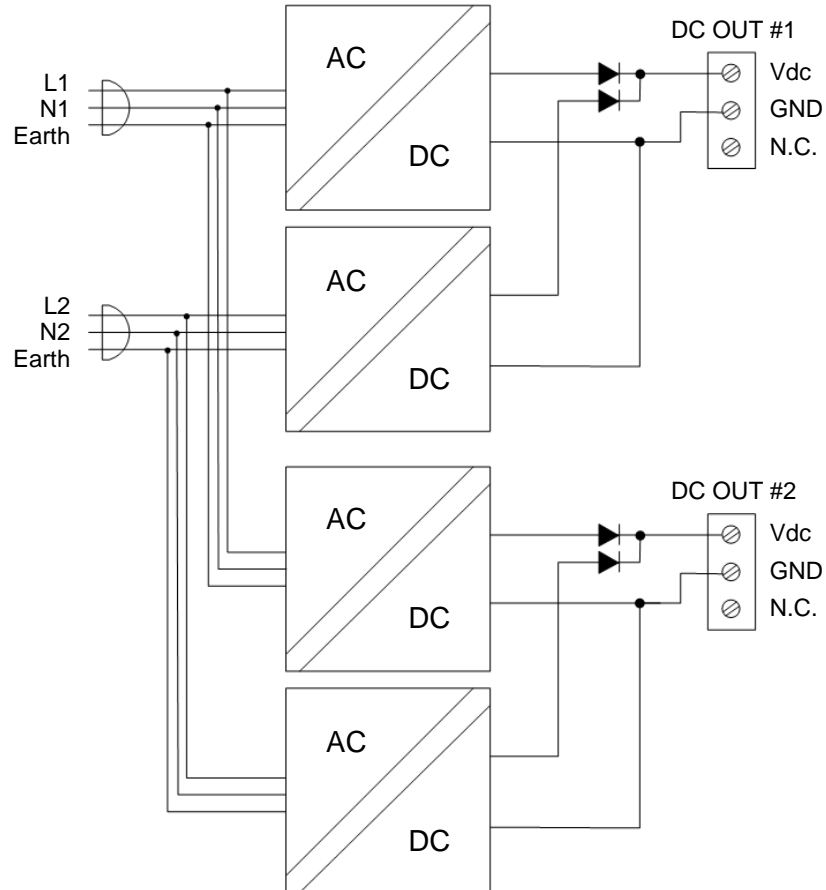

SPECIFICATIONS

Electrical

Input voltage range	: 88 to 264 V <sub>AC</sub> (47 to 63 Hz) or 125 to 373 V <sub>DC</sub> The ASPS takes its AC mains supply from an adjacent RPS 6U rack power supply unit (AC version) in the same VM600 rack. Therefore, refer also to the input voltage range specified in the RPS 6U data sheet.
Current Consumption	
• AC	: 0.40 A at 230 V <sub>AC</sub> / 0.7 A at 115 V <sub>AC</sub>
Nominal output	
• Voltage	: 2 x 24 V <sub>DC</sub> (the two outputs can be connected in parallel)
• Current	: 2 x 1.1 A (the two outputs can be connected in parallel)
• Power	: 52.8 W max. (2 x 26.4 W)
Stability of the output	: 1.0% (for 10 to 100% load variation)
Ripple (output voltage noise)	: 80 mV (peak to peak)
Protection against permanent short-circuit (current limit)	: Yes

**SPECIFICATIONS**

---

**Environmental**

Temperature range

- *Operation* : -25 to +65°C (-14 to +149°F)
- *Storage* : -40 to +85°C (-40 to +185°F)

Relative humidity (non-condensing) : &lt;90%

MTBF : &gt;300000 hours, according to IEC 1709 (SN 29500)

**Connectors**Conductor cross-section : ≤1.5 mm<sup>2</sup> (max.)**Physical**

Dimensions

- *Height* : 6 U (262 mm, 10.3 inches)
- *Width* : 40 mm (1.6 inches)
- *Depth* : 110 mm (4.3 inches)

Weight : 890 g approx.

**ORDERING INFORMATION**

---

To order please specify

Type	Designation	Ordering number
ASPS	Auxiliary sensor power supply	200-582-810-0Hh

Note: "Hh" represents the hardware version, where "H" increments are for major modifications that can affect product interchangeability and "h" increments are for minor modifications that have no effect on interchangeability.

Headquartered in the UK, Meggitt PLC is a global engineering group specializing in extreme environment components and smart sub-systems for aerospace, defence and energy markets.

Meggitt Sensing Systems is the operating division of Meggitt specializing in sensing and monitoring systems, which has operated through its antecedents since 1927 under the names of ECET, Endevo, Ferroperm Piezoceramics, Lodge Ignition, Sensorex, Vibro-Meter and Wilcoxon Research. Today, these operations are integrated under one strategic business unit called Meggitt Sensing Systems, headquartered in Switzerland and providing complete systems, using these renowned brands, from a single supply base.

The Meggitt Sensing Systems facility in Fribourg, Switzerland was formerly known as Vibro-Meter SA, but is now Meggitt SA. This site produces a wide range of vibration and dynamic pressure sensors capable of operation in extreme environments, leading-edge microwave sensors, electronics monitoring systems and innovative software for aerospace and land-based turbo-machinery.



All statements, technical information, drawings, performance rates and descriptions in this document, whilst stated in good faith, are issued for the sole purpose of giving an approximate indication of the products described in them, and are not binding on Meggitt SA unless expressly agreed in writing. Before acquiring this product, you must evaluate it and determine if it is suitable for your intended application. Unless otherwise expressly agreed in writing with Meggitt SA, you assume all risks and liability associated with its use. Any recommendations and advice given without charge, whilst given in good faith, are not binding on Meggitt SA.

Meggitt Sensing Systems takes no responsibility for any statements related to the product which are not contained in a current Meggitt Sensing Systems publication, nor for any statements contained in extracts, summaries, translations or any other documents not authored by Meggitt Sensing Systems. We reserve the right to alter any part of this publication without prior notice.

In this publication, a dot (.) is used as the decimal separator and thousands are separated by thin spaces. Example: 12345.67890.

## Sales offices

Meggitt Sensing Systems has offices in more than 30 countries. For a complete list, please visit our website.



ISO 9001  
FS 584089



## Your local agent

## Head office

**Meggitt SA**  
Route de Moncor 4  
PO Box 1616  
CH - 1701 Fribourg  
Switzerland

Tel: +41 26 407 11 11  
Fax: +41 26 407 13 01

[www.meggittsensingsystems.com](http://www.meggittsensingsystems.com)  
[www.vibro-meter.com](http://www.vibro-meter.com)